



**Mega Catch**<sup>TM</sup>

# Mosquito Trap



**Operation Manual**  
**Ultra** Model MCU400

## Contents

## Page

Important Safety Instructions	1
Introduction	2
Features of Mega-Catch™ <b>ULTRA</b> Mosquito Trap	2-3
Initial Set Up Instructions	3-5
What Your Mega-Catch™ Mosquito Trap Will Do	5
Installing and Siting the Mega-Catch™ Mosquito Trap	5-6
Mega-Catch™ Trolley	7-9
Stand Assembly Instructions	10
Mega-Catch™ Variable Quantity Slow CO <sub>2</sub> Gas Release System	11
Connecting the <b>ULTRA</b> to the CO <sub>2</sub> Gas Supply	12
Operation of Variable Quantity Slow CO <sub>2</sub> Gas Release System	13-14
CO <sub>2</sub> Gas Suppliers	14
Operation of the Programmable Timer	15-16
Mosquito Catching Systems	17
Using the Liquid Catch Container	17
Using the Catch Bag	18
Fitting of External Skirt	19
Care of Your Trap	20-21
Replacement of U.V. Bulb	21
Mega-Catch™ Octenol Fragrance Strip	22
Optional Accessories	23
Maintenance and Repair of Your Trap	24-26
Disposal of Nickel-Cadmium Batteries	27
Frequently Asked Questions	28
Problem Solving	29
Specifications	29
Parts List	30

## Important Safety Instructions

- Do not operate the Trap indoors.
- Keep children and pets away from the Trap.
- When the Trap is not in use disconnect power, turn off CO<sub>2</sub> gas and store the Trap and Gas Cylinder out of reach of children.
- Always disconnect power before cleaning, servicing or inspecting the inside of the Trap.
- To avoid injury from the High-Speed Fan inside the Trap, always disconnect power before opening the Door. Keep the Door locked and remove the Key while the Trap is operating.
- Plug the Power Cord into a properly grounded electrical outlet protected from weather.
- Do not allow the Trap, Transformer, Power Cord or plug to be immersed in water.
- Do not operate the Trap with a damaged Transformer, Power Cord or plug.
- Do not use any extension cord other than the Extension Cord supplied with the Trap.
- Ensure Power Cords are placed carefully to avoid causing a tripping hazard.
- Ensure the Trap is properly installed in accordance with this operation manual.
- Before installing or removing the CO<sub>2</sub> Gas Regulator, always ensure that the CO<sub>2</sub> gas is turned off at the Gas Cylinder.
- Read and follow instructions in this operation manual carefully before operating the Trap.

## SAFETY INSTRUCTIONS

## Introduction

Mosquitoes have been described as the most dangerous creatures on Earth.

Aedes mosquitoes may carry yellow fever and dengue fever. Culex mosquitoes may carry several strains of encephalitis (including St. Louis Encephalitis, Eastern Equine Encephalitis and West Nile Virus), and Anopheles mosquitoes may carry malaria.

Male mosquitoes do not bite. The real risk is from female mosquitoes which bite when in search of blood to provide protein for their eggs.

Scientific research over the past 50 years has shown that female mosquitoes find their prey using a combination of sensory cues including light, shape, color, heat, vibration, sweat and other by-products of human activity.

Using that research and with the benefit of extensive field testing (including tests by the United States Department of Agriculture in Gainesville, Florida), Mega-Catch™ has developed what is arguably the world's most advanced mosquito trap: the Mega-Catch™ **ULTRA** Mosquito Trap.

## Features of Mega-Catch™ **ULTRA** Mosquito Trap

The Mega-Catch™ **ULTRA** Mosquito Trap has been designed for outdoor use only. The **ULTRA** can operate unattended for long periods. It can be programmed to start and stop according to peak mosquito activity in your area. It features an electronically controlled diode lighting system that produces intermittent light at oscillating frequencies selected to coincide with spectral sensitivity peaks for many mosquito species. It also features a low-intensity U.V. or black light Bulb.

Mosquitoes attracted to the **ULTRA** by visual and other cues seek to land on and probe specially designed surfaces and enter the Trap where they are collected in the Catch Bag or Liquid Catch Container.

The **ULTRA** also features the Mega-Catch™ **Variable Quantity Slow CO<sub>2</sub> Gas Release System**. This system enables the **ULTRA** to replicate a key element of human respiration by releasing small quantities of carbon dioxide (CO<sub>2</sub>) gas at an exponentially decaying (negative) rate over fixed intervals to produce a concentration gradient in the air plume emanating from the lower part of the Trap. The CO<sub>2</sub> plume will, in optimum conditions, attract mosquitoes from a distance of up to 150 feet (45 meters). Mosquitoes navigate their way to the Trap by following the CO<sub>2</sub> gas plume up wind.

CO<sub>2</sub> is a natural product of human respiration and entirely safe in the small quantities

dispensed from the **ULTRA** Trap.

CO<sub>2</sub> is used in food and beverage production and is able to be purchased from gas supply outlets throughout the U.S.A. (see **CO<sub>2</sub> Gas Suppliers** section).

Quantities of CO<sub>2</sub> gas released by the **ULTRA** can be adjusted between 5 settings by a simple touch of the Gas Select Button on the Programmable Timer. A 201b (9kg) CO<sub>2</sub> Gas Cylinder used at the recommended settings should last for up to 5 months (see **Operation of Variable Quantity Slow CO<sub>2</sub> Gas Release System** section).

## Initial Set Up Instructions

Before attempting operation of your **ULTRA** Trap, follow these instructions:

1. Remove the Trap from the carton.
2. Remove the box containing the Stand from the carton.
3. Assemble the Stand (see **Stand Assembly Instructions** section).
4. Remove the box marked Accessories from the base of the carton. This is located beneath the bottom polystyrene packers.
5. Hang the Trap from the hook on the Stand as shown in the Stand Assembly Instructions.
6. Fit the External Skirt to the outside of the Trap by pulling the Skirt up from the base of the Trap so that the opening is directly in front of the Door (see **Fitting of External Skirt** section).  
Note: Failure to position the Skirt correctly will result in a **NIL** mosquito catch.
7. Your **ULTRA** Trap has two mosquito collection methods: a dry-catch system using a Catch Bag and a wet catch system using a Catch Container. In most circumstances the wet-catch system offers superior catch performance to the dry-catch system. The dry-catch system using the Catch Bag is better for mosquito species identification.
8. If you wish to catch mosquitoes using the Catch Bag, then attach the Catch Bag to the base of the Fan inside the Trap. The Catch Bag has an elastic top to facilitate attachment (see **Mosquito Catching Systems** section).

9. If you wish to catch mosquitoes using the wet-catch system, fill the Liquid Catch Container two-thirds full with fresh water. Add 2 or 3 drops of liquid detergent / soap to break the surface tension of the water. Also add 3 or 4 teaspoons of a non-diet (sugar-based) soft drink. Then place the Liquid Catch Container in the Trap using the locating feet on its base.
10. Remove the Mega-Catch™ Octenol Fragrance Strip from its pouch being careful not to touch the exposed holes on its surface. Place the Strip inside the Trap (see **Mega-Catch™ Octenol Fragrance Strip** section). Wash your hands after this procedure has been completed.
11. Reinstall the Door by locating the base of the Door in the Trap and then pushing firmly until Door clicks into place. Lock the Door using one of the two Keys provided with the Trap and then remove the Key. (NOTE: Removing and reinstalling the door is designed to require a reasonable amount of force to make it difficult for children.)
12. The **ULTRA** Trap comes with the Mega-Catch™ Variable Quantity Slow CO<sub>2</sub> Gas Release System. Use of this system is entirely **optional** (see **Mega-Catch™ Variable Quantity Slow CO<sub>2</sub> Gas Release System** section). If using the Mega-Catch™ Variable Quantity Slow CO<sub>2</sub> Gas Release System then you will first need to obtain a CO<sub>2</sub> cylinder (see **CO<sub>2</sub> Gas Suppliers** section). Having obtained a CO<sub>2</sub> cylinder, connect the Low-Pressure Gas Regulator (supplied with the Trap) to the Gas Cylinder ensuring beforehand that the "O" ring on the Gas Regulator is properly in place and undamaged. Then connect the Regulator to the Trap (see **Connecting the ULTRA to the CO<sub>2</sub> Gas Supply** section). Slowly turn on the CO<sub>2</sub> gas checking for leaks. Set the gas setting using the "Gas Select" button on the Programmable Timer (see **Operation of Variable Quantity Slow CO<sub>2</sub> Gas Release System** section). Setting #1 is low. Setting #5 is high. (Note: you will need to reset the gas setting if the power is turned off).
13. Your **ULTRA** Trap comes with a low-voltage transformer and a 60-foot (18-meter) low-voltage extension cord with weatherproof connectors. Plug the extension cord into the Trap connection turning the connector clockwise until tight. Plug the extension cord into the transformer cable turning the connector clockwise until tight. Then plug into the power supply. (NOTE: The connectors are designed to be a tight fit to ensure that they are weatherproof.)
14. Turn on the power. A display should appear on the face of the Timer. (If it does not, see **Operation of the Programmable Timer** section). Set the Timer to "ON" for continuous running or to "AUTO" to program operating times. See **Operation of the Programmable Timer** section for programming instructions.

15. If the U.V. Bulb inside the Trap is not on then turn it on by touching the switch on the Programmable Timer which is marked "U.V. Tube". When the Trap is operating, the Fan should be running, the four Diode Lights should be flashing intermittently, the U.V. Bulb should be on (unless switched off) and the Trap should "click" every 75-80 seconds. If the Trap is not operating correctly then re-read these instructions or refer to the **Problem Solving** section, or email us at [info@megacatch.com](mailto:info@megacatch.com).

## What Your Mega-Catch™ Mosquito Trap Will Do

Your Mega-Catch™ Mosquito Trap is designed to reduce mosquito populations. Operate the Mega-Catch™ Mosquito Trap daily for several weeks. Over this time you should notice a decline in mosquito numbers. This means your Trap is doing its job.

You may discontinue operation of the Trap once your mosquito problem is under control. When mosquitoes enter your area again (probably from a new infestation after rain), begin operating your Mega-Catch™ Mosquito Trap again.

The Mega-Catch™ Mosquito Trap is not designed to compete with humans in close proximity eg: at a barbecue. If you are planning an outdoor function, operate the Trap for several days before the function.

## Installing and Siting the Mega-Catch™ Mosquito Trap

### Installation of Trap:

Your Mosquito Trap comes fully assembled. To install, first follow the instructions under the **Initial Set Up Instructions** section.

The Initial Set Up Instructions assume that you have decided to install your Mega-Catch™ Mosquito Trap on the Stand that is supplied with the Trap.

Alternatively, you may choose to install the Trap on a Mega-Catch™ Trolley which can be purchased as an optional extra (see **Mega-Catch™ Trolley** section).

Alternatively you may decide to hang the Trap from a tree or a fixed post using a chain, nylon rope or wire connected to the attachment hole at the top of the Trap. We recommend a height of around 3 feet from the ground to the top of the Mega-Catch™ Mosquito Trap. However, you may need to adjust the Trap's height depending on the type of mosquitoes you are catching.

Your Mega-Catch™ Mosquito Trap is supplied with a 60-foot (18-meter) Low-Voltage Extension Cord with weatherproof fittings. To avoid the cord posing a tripping hazard or being damaged, (e.g. by a lawn mower) we recommend that, if possible, it be placed 2-3 inches underground. This can be easily achieved by using a spade which is inserted into the ground and moved backwards and forwards to create a shallow slit trench into which the cord can be pushed before the ground is replaced by standing on the top of the slit trench.

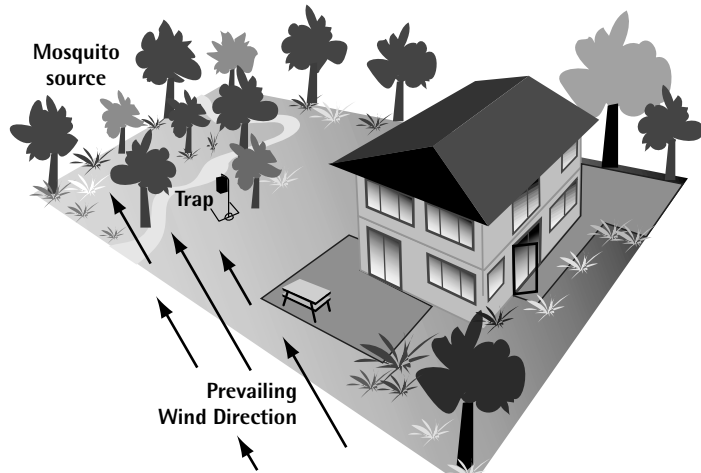

**Siting of Trap:**

**FIG 1 - Trap Positioning**

For the best performance from your Mega-Catch™ Mosquito Trap, first determine the source of the mosquito nuisance (Mosquitoes breed in wet areas like streams, marshland, wooded areas and gardens). Then use these rules to site the Trap:

- Rule 1:** Place the Trap between the mosquito source and areas of human activity
- Rule 2:** Place the Trap as far away from people and as close to the mosquito source as possible. (Attract them to the Trap and not to you.)
- Rule 3:** Place the Trap upwind of the mosquito source but only if you can comply with Rule 1. (Mosquitoes sometimes use the wind to navigate.)
- Rule 4:** Place the Trap in a predominantly shaded area. (Most mosquitoes avoid direct sunlight.)
- Rule 5:** Place the Trap in a location protected from rain and strong wind. (Mosquitoes don't fly in strong winds.)
- Rule 6:** If severe weather conditions are predicted then store the Trap out of the weather.

## Mega-Catch™ Trolley

The Mega-Catch™ Trolley is an optional extra for use in conjunction with the **ULTRA** Trap. Assembly of the Mega-Catch™ Trolley is a simple procedure if you follow the directions shown in figures 2.1 to 2.3 below:

**FIG. 2.1 Trolley assembly**

When trolley assembly is complete, hang trap from hook through fitting on top of the unit, then connect powerplug and gas line

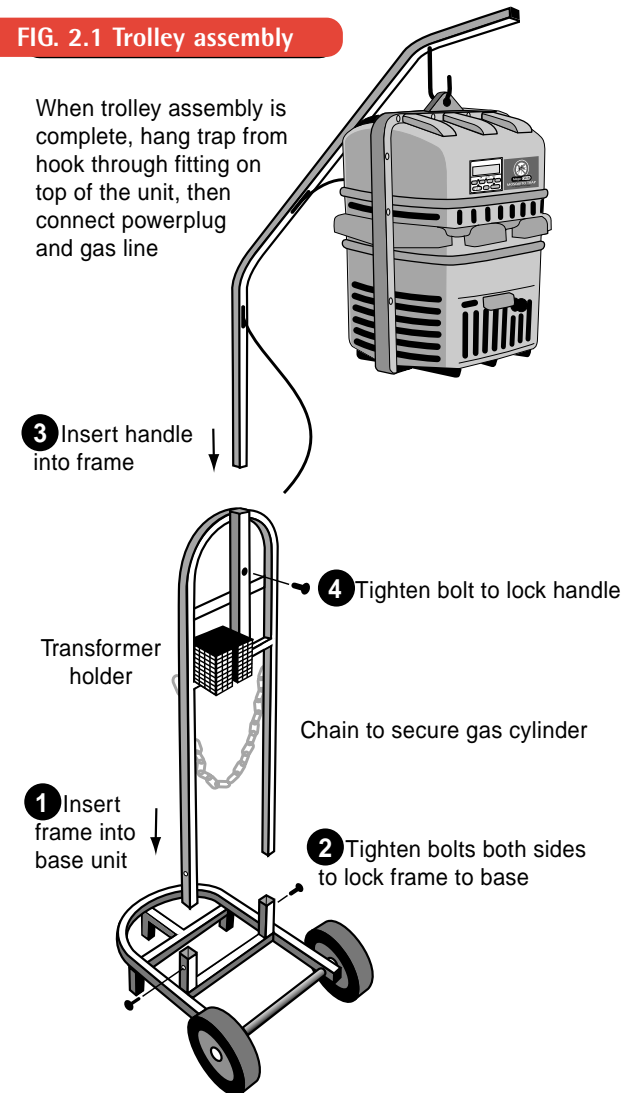

**FIG. 2.2 Trolley assembly**

complete with CO<sub>2</sub> gas cylinder and transformer installed

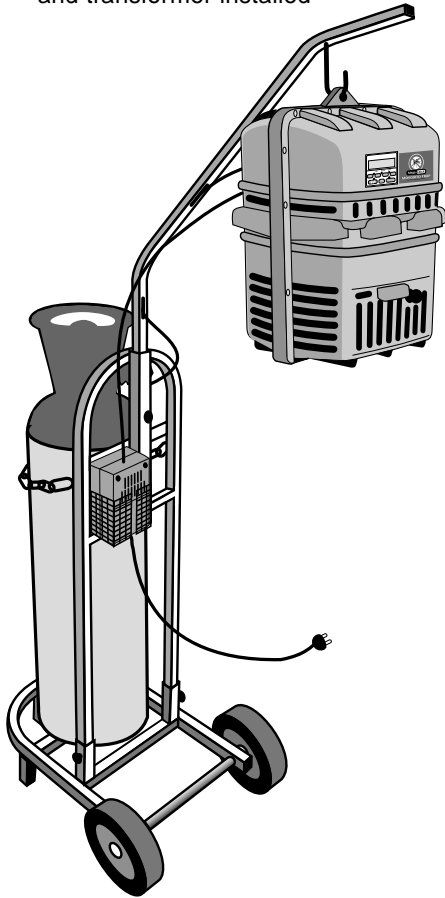

**FIG. 2.3 Trolley assembly**

complete with weatherproof cover fitted

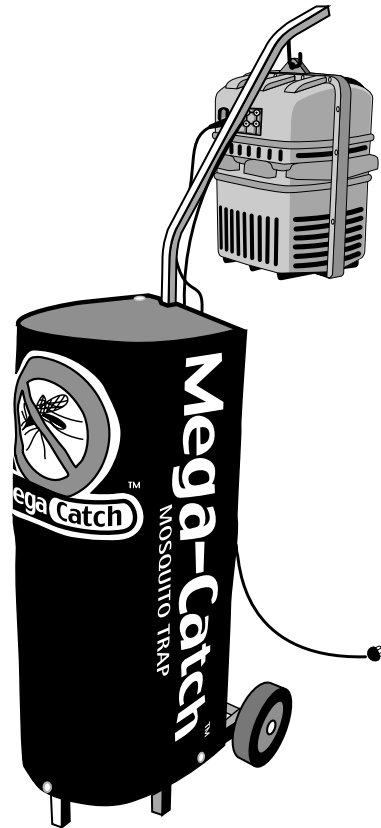

The Mega-Catch™ Trolley has been designed to hold a 20 lb (9kgs) CO<sub>2</sub> Gas Cylinder for use in conjunction with the **ULTRA** Trap.

If you wish to install a Mega-Catch™ Mosquito Trap on a Mega-Catch™ Trolley without a CO<sub>2</sub> Gas Cylinder in place then the handle on the Trolley should be reversed. We also recommend that a stability weight (eg: a cement/cinder block of at least 10 lbs (4.5 kgs)) be placed on the Trolley in the manner shown in figure 2.4 below:

Your Mega-Catch™ Trolley has been zinc-plated and powder-coated for outdoor use. However, when not in use, we recommend that it be stored out of the weather.

**FIG. 2.4 Trolley assembly option**

for use without CO<sub>2</sub> gas cylinder

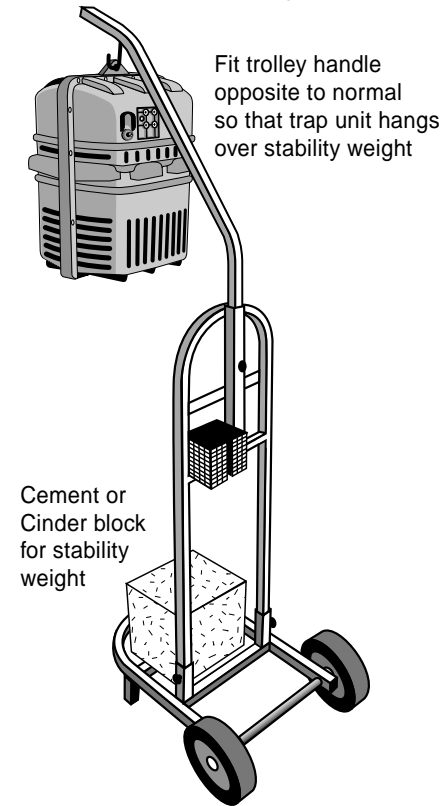

## Stand Assembly Instructions

To assemble the Stand supplied with the Trap, follow the instructions shown in figure 3.1. below.

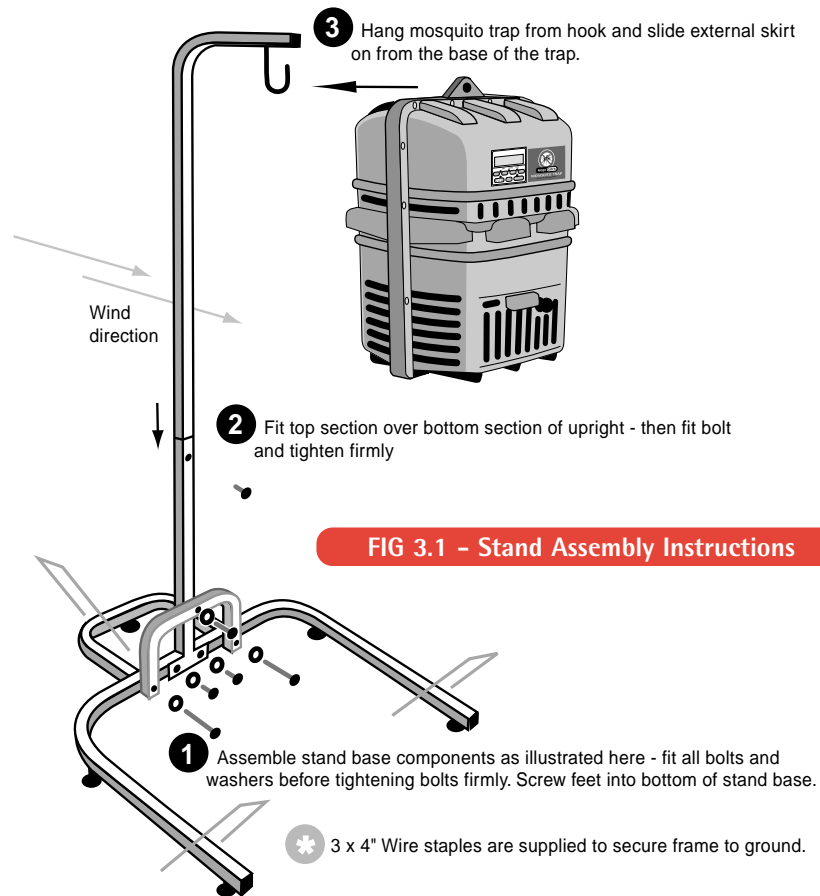

**NOTE:** For optimum performance place the trap in a predominantly shaded area (located between your dwelling and the source of the mosquitoes) which is protected from rain and wind. (Mosquitoes do not fly in strong winds or severe weather conditions.) For maximum stability the 'U' shaped leg at the back of the stand should be pointed in the direction of prevailing winds. The wire staples supplied with the trap (or a cinder block placed on the back of the stand) can be used to increase stability.

For maximum stability, point the small "U" shaped leg at the back of the Stand into the prevailing wind and pin the base to the ground using the wire staples supplied with the Stand.

While your Mega-Catch™ Stand is zinc-plated and powder-coated, when not in use, we recommend that it be stored out of the weather.

## Mega-Catch™ Variable Quantity Slow CO<sub>2</sub> Gas Release System

Mosquitoes find their prey using a vast array of sensory signals including light, shape, colour, heat, vibration and various chemical compounds produced by humans and other animals. One of these compounds is carbon dioxide or CO<sub>2</sub>. Most conventional traps rely on CO<sub>2</sub> gas to attract mosquitoes. They usually achieve this by burning flammable liquids like propane. Carbon dioxide gas is one by-product of that combustion process.

Mega-Catch™ Traps on the other hand need no CO<sub>2</sub> to attract mosquitoes. Using advanced design features and sophisticated electronic componentry, Mega-Catch™ Traps exploit a wide range of sensory signals to attract mosquitoes.

Mega-Catch™ also offers its own carbon dioxide attractant system using its patented "Variable Quantity Slow CO<sub>2</sub> Gas Release System". The latest version of this system is now a standard feature on all Mega-Catch™ **ULTRA** model Traps.

Use of this system is entirely **optional** i.e. while the system is designed to increase capture rates it is not essential to the effective operation of the Trap. Even without the system, or with the system turned off, your Mega-Catch™ **ULTRA** Mosquito Trap will catch significant numbers of mosquitoes and other biting insects.

Conventional Traps which burn propane release CO<sub>2</sub> gas in a continuous stream as part of the exhaust gases from the propane combustion process. Mega-Catch™'s **Variable Quantity Slow CO<sub>2</sub> Gas Release System** is designed to replicate a key element of human respiration by releasing quantities of pure CO<sub>2</sub> gas at an exponentially decaying (negative) rate over fixed intervals to produce a concentration gradient in the air plume emanating from the lower part of the Trap. Mosquitoes use this concentration gradient to navigate their way to the Trap.

The Mega-Catch™ system is able to release more CO<sub>2</sub> (and in a cleaner and purer form) than propane burning traps by using carbon dioxide in the same cylinders as those used by the beverage industry to aerate (put bubbles into) the likes of beer, cola and mineral water. CO<sub>2</sub> gas in this form is able to be purchased from hundreds of gas supply outlets throughout the U.S.A. (see **CO<sub>2</sub> Gas Suppliers** section.)

**WARNING: DO NOT OPERATE THE TRAP INDOORS**

## Connecting the ULTRA to the CO<sub>2</sub> Gas Supply

Before attempting to use the Variable Quantity Slow CO<sub>2</sub> Gas Release System you must first follow these instructions (also see figure 3.2 below).

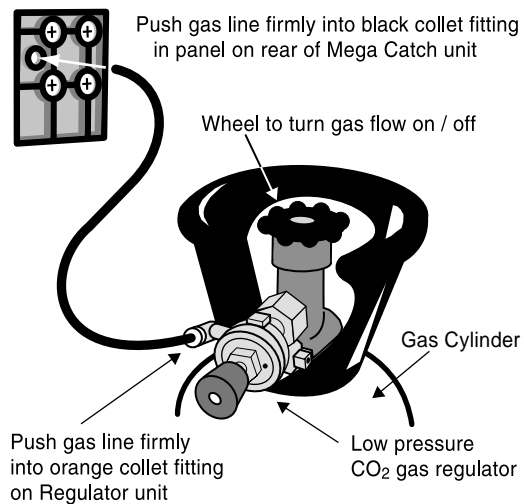

**FIG. 3.2 Connection of Trap to CO<sub>2</sub> gas cylinder**

1. The **ULTRA** comes with a Low-Pressure CO<sub>2</sub> Gas Regulator and a length of Low-Pressure Gas Line to connect the Regulator to the Trap.
2. Check to ensure that the "O"-ring on the Gas Regulator is properly in place and undamaged. (Note: the gas pressure setting of the Gas Regulator has been set in the factory and cannot be adjusted. For this reason the knob on the Gas Regulator is redundant, i.e. turning the knob has no effect on the operation of the Gas Regulator).
3. Attach the Gas Regulator onto the threaded section of the Gas Cylinder and tighten firmly using a suitable sized wrench. Note: if the threads do not match then contact your gas supplier. (see **CO<sub>2</sub> Gas Suppliers** section.)

**Warning: Do not turn on the CO<sub>2</sub> gas supply from the Gas Cylinder until you have fitted the Low-Pressure Gas Regulator. Direct contact with liquid CO<sub>2</sub> may result in serious tissue damage. CO<sub>2</sub> Gas Cylinders (empty or full) which do not have a Low-Pressure Regulator firmly connected should be securely locked away out of reach of children. We recommend that CO<sub>2</sub> Gas Cylinders be moved around using a Mega-Catch™ Trolley which has been specially designed for this purpose.**

4. Push one end of the gas line firmly into the orange collet fitting on the Gas Regulator unit. Push the other end of the gas line firmly into the black collet fitting in the panel on the rear of the Mega-Catch™ unit (see figure 3.2). Gradually turn on the CO<sub>2</sub> gas by turning the wheel on the top of the Gas Cylinder in an anti-clockwise direction.
5. Check for gas leaks from the Gas Cylinder, the Regulator and the gas line using a small quantity of liquid detergent or liquid soap thoroughly stirred in some water (simply brush or pour this over the items to be checked). A gas leak can be detected by the appearance of bubbles. If a leak is detected then turn off the CO<sub>2</sub> gas by turning the wheel on the Gas Cylinder clockwise. Then disconnect the Gas Regulator and check that the "O" ring seal is in place and is undamaged and then repeat the process. If there is still a leak from the Gas Cylinder or the Gas Regulator refer to your gas supplier (see **CO<sub>2</sub> Gas Supplier** section.) or email us (info@megacatch.com).
6. To remove the gas line simply use two fingers to push the sides of the plastic collet fitting inwards then, using the other hand, firmly pull the gas line out of the collet fitting. If the line is damaged replace it. If however the damage is restricted to the end of the line simply cut out the damaged area. (Note: the collets are the orange fitting at the Regulator connection and the black fitting at the Trap connection). See figure 3.2.

**WARNING: BEFORE INSTALLING OR REMOVING THE GAS REGULATOR ALWAYS ENSURE THE GAS IS TURNED OFF BY TURNING THE ON/OFF WHEEL ON THE GAS CYLINDER CLOCKWISE.**

## Operation of Variable Quantity Slow CO<sub>2</sub> Gas Release System

You can adjust the quantity of CO<sub>2</sub> gas being released from the **ULTRA** Trap by a simple touch of the GAS SELECT button on the Programmable Timer. When the power is first turned on the Trap automatically selects setting # 1 which is the lowest gas usage quantity. The GAS SELECT button should be touched once to move to the next setting (indicated by the red light glowing on the setting chosen). Touch the GAS SELECT button for the number of times necessary to move to the setting # you wish to select.

**Remember to reset the setting # after each time the power is switched off.**

On setting # 1, a 20 lb (9kgs) CO<sub>2</sub> Gas Cylinder can be operated **continuously** for almost 12 months. Continuous use of the Trap on higher settings can waste CO<sub>2</sub> gas. We recommend that the Trap be operated for no more than 8 hours a day at times so as to coincide with peak mosquito activity. This might be increased to 12 hours a day if you are experiencing a particularly heavy infestation of mosquitoes.

If you operate your Mega-Catch™ Mosquito Trap in accordance with our recommendation of no more than 8 hours per day, then you can expect a 20 lb (9kgs) CO2 Gas Cylinder to last as follows:

Gas Select #	Approximate Duration
# 1	In excess of 1 year
# 2	150 days
# 3	50 days
# 4	30 days
# 5	25 days

We recommend that you choose setting # 2 or # 3 for normal Trap operation. In preparing for an outdoor function, you might wish to operate the Trap on setting # 4 or # 5 for a limited period, eg: 12 hours per day for 2 or 3 days.

## CO<sub>2</sub> Gas Suppliers

Mega-Catch™ Mosquito Traps equipped with the Variable Quantity Slow CO<sub>2</sub> Gas Release System (standard on the **ULTRA**) use CO<sub>2</sub> gas which can be purchased from hundreds of gas supply outlets throughout the U.S.A. Major gas distributors include PraxAir, Air Products, BOC Gases and Air Liquide. Refer to our website: [www.megacatch.com](http://www.megacatch.com) for store locations of major CO<sub>2</sub> gas distributors in the U.S.A.

We recommend that you purchase CO<sub>2</sub> in 20 lb (9 kgs) aluminium cylinders.

## Operation of the Programmable Timer

Your Mega-Catch™ Mosquito Trap is equipped with a high tech Programmable Timer. The Timer enables you to program the Trap to operate at times when mosquitos are most active in your area.

The Timer is equipped with an automatically recharging battery. This battery can operate for up to three months when fully charged.

Your Mega-Catch™ Mosquito Trap may need several hours of running to charge up the battery upon initial use.

NOTE: If no display appears on the Programmable Timer when the power is switched on, the battery may be discharged. To fully recharge the battery, run the Trap for 24 hours.

You can choose to operate the Mega-Catch™ Mosquito Trap in 3 ways:

1. **ON** – The Mega-Catch™ Mosquito Trap will run 24 hours a day while connected to a power source.
2. **OFF** – the Mega-Catch™ Mosquito Trap will not operate.
3. **AUTO** – you can program when the Mega-Catch™ Mosquito Trap will start and stop.

### How to Program:

FIRST SET THE TIME.

To set the day and time, press and hold the **CLOCK** button while pressing the **DAY** or **HOUR** or **MINUTE** button (as the case requires). This is the only function that requires two buttons to be pressed at once.

THEN PRESS PROGRAM TO START PROGRAMMING.

Start time program 1. Enter start time with **HOUR**/**MINUTE** buttons. For 7 days per week operation select the **DAY** display, which shows all 7 days. For individual day operation select the **DAY** display desired, e.g. **Su** for Sunday.

THEN PRESS PROGRAM.

Stop time program 1. Enter stop time with **HOUR**/**MINUTE** buttons.

THEN PRESS PROGRAM.

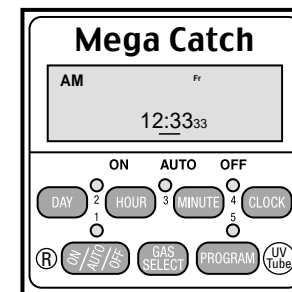

FIG 4.1

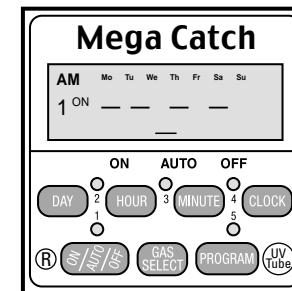

FIG 4.2

Start time program 2. Enter start time with HOUR/MINUTE buttons.

THEN PRESS PROGRAM.

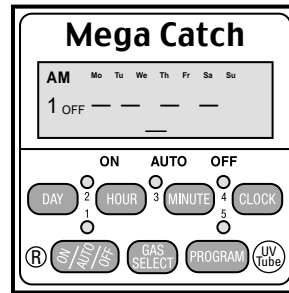

FIG 4.3

Stop time program 2. Enter stop time with HOUR/MINUTE buttons. To enter more programs (up to 6) repeat previous steps.

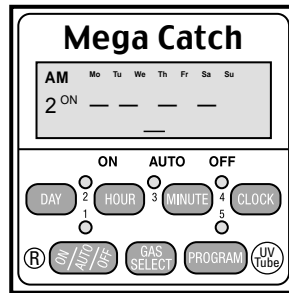

FIG 4.4

THEN PRESS CLOCK TO RETURN TO NORMAL OPERATION.

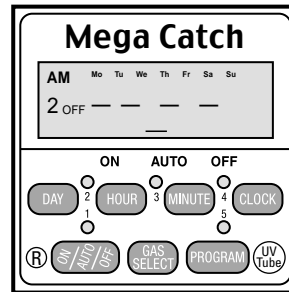

FIG 4.5

Press the ON/AUTO/OFF button to change position of the mode indicator.

ON = system will be operating at all times.

AUTO = system will be operating only during programmed times.

OFF = system will not operate at all

NOTE: If the Trap does not operate when the program mode is set to AUTO it is probably because it may be in "stop time program." To check, switch the program mode to ON, which should start the Trap, before returning the program mode to AUTO.

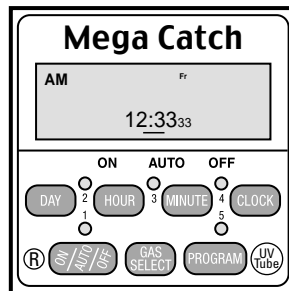

FIG 4.6

Your Mega-Catch™ Mosquito Trap comes complete with a Catch Bag and a Liquid Catch Container. You may choose to collect mosquitoes using either of these systems. Our research has shown the Liquid Catch Container system to be more effective. This is because when the Mega-Catch™ Mosquito Trap is operated using a Liquid Catch Container, the air plume emanating from the bottom of the Trap is humidity enriched. Depending on local temperatures, evaporation may mean that it is necessary to replenish water in the Liquid Catch Container weekly or even more frequently. The Catch Bag system requires less frequent attention and therefore may be your preferred mosquito catching system. Smaller biting insects (eg: no-see-ums) are best caught using the Liquid Catch Container because the mesh size on the standard Catch Bag may be too large to capture them.

### Using the Liquid Catch Container

To prepare your Mega-Catch™ Mosquito Trap, follow these steps:

1. Ensure that the Trap is switched off by disconnecting the power. **(Attention: High-Speed Fan inside the Trap may cause injury if the power is not disconnected.)**
2. Unlock and remove the Lockable Door.
3. Slide the Liquid Catch Container out from beneath the Fan. This container has locating feet on its base.
4. Fill the container with water until it is approximately two-thirds full. Add 3 or 4 drops of liquid detergent/soap and stir thoroughly. This breaks the surface tension of the water ensuring that mosquitoes drown upon capture.
5. Add 3 or 4 teaspoons of a non-diet (sugar-based) soft drink. This duplicates the fructose content of nectar on which mosquitoes feed.
6. Reinstall the Liquid Catch Container into the Mega-Catch™ Mosquito Trap. Replace and lock the Door and remove the Key for child safety. Reconnect power.
7. Before removing the Liquid Catch Container, remember to disconnect the power to your Mega-Catch™ Mosquito Trap so that the Fan is not operational. Dispose of the contents well away from your dwelling so as to not attract ants.

It may be necessary to replenish or replace the water solution in the Liquid Catch Container at weekly or more frequent intervals to take account of evaporation. This will depend on relevant climatic conditions.

## Using the Catch Bag

To prepare your Mega-Catch™ Mosquito Trap, follow these steps:

1. Ensure that the Trap is switched off by disconnecting the power (**Attention: High-Speed Fan inside the Trap may cause injury if the power is not disconnected.**)
2. Unlock and remove the Lockable Door.
3. Reach inside the Trap and stretch the open neck of the Catch Bag around the corners of the base of the Fan just above the Fan Safety Guard (see figure 5). The Catch Bag has an elastic neck to facilitate attachment.
4. Replace and lock the Door and remove the Key for child safety. Reconnect power.
5. Before removing the Catch Bag, remember to disconnect the power to your Mega-Catch™ Mosquito Trap so that the Fan is not operational. Then pull the drawstring tight so that any mosquitoes that remain alive cannot escape. Crush the top of the Catch Bag down on its base to kill any mosquitoes that do remain alive. Dispose of the contents well away from your dwelling so as not to attract ants.

Mosquitoes collected in the Catch Bag will usually die very quickly without access to moisture. In cooler climates they may live for a longer period. In times of heavy infestations of mosquitoes, it may be necessary to empty the Catch Bag on a regular basis in order to ensure optimum operation of the Trap.

FIG 5 - Fitting of Catch Bag

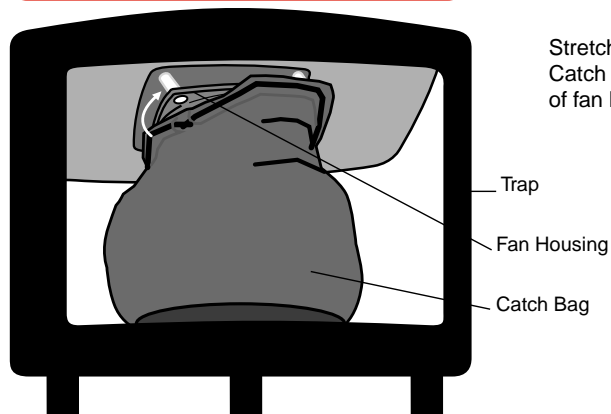

Catch Bags should be hand washed in warm soapy water from time to time. Replacement Catch Bags are a consumable item and are available from your Authorized Distributor.

## Fitting of External Skirt

Your Mega-Catch™ Mosquito Trap comes with an External Skirt which fulfils two important functions. First its color and texture provides a visual attractant for several species of mosquitoes. Secondly, it acts as a baffle directing the air plume out of the bottom of the Trap.

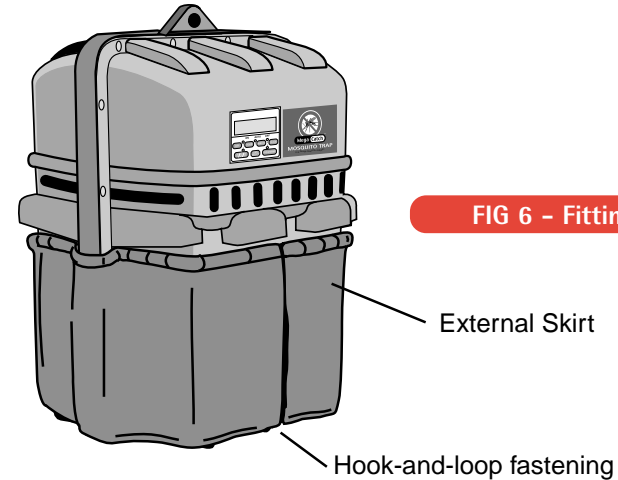

FIG 6 - Fitting External Skirt

There are two methods which you can use to fit the Skirt:

### Method One:

1. Hang the Mega-Catch™ Mosquito Trap from the Stand (see **Stand Assembly Instructions** section).
2. Slide the Skirt up from the bottom of the Trap (over 2 corners initially) with the elastic band at the top.
3. The Skirt is properly fitted when the elastic band is seated over the lower horizontal rib, just below the inlet holes (see figure 6). The opening in the Skirt should be located at the front of the Trap so as to facilitate removal of the Door without having to remove the Skirt. The hook-and-loop fastening on this opening should be closed when the Trap is running.

### Method Two:

1. Place the Mega-Catch™ Mosquito Trap on a table or other flat surface.

2. Slide the Skirt on from the top of the Trap (over 2 corners initially) with the elastic band at the top.

3. The Skirt is properly fitted when the elastic band is seated over the lower horizontal rib, just below the inlet holes (see figure 6). The opening in the Skirt should be located at the front of the Trap so as to facilitate removal of the Door without having to remove the Skirt. The hook-and-loop fastening on this opening should be closed when the Trap is running.

The Skirt is not manufactured from a U.V.-resistant material, but this will not be an issue if the Trap is operated in shaded conditions as recommended. The Skirt can be reversed should one side begin to fade from exposure to U.V. light. The Skirt is a consumable item and replacements can be obtained from your Authorized Distributor.

### Care of Your Trap

Your Mega-Catch™ Mosquito Trap requires very little maintenance. The Catch Bag and Liquid Catch Container should be cleaned and washed when required. Heavy catches of mosquitoes may result in a build-up of material in the internal casing and blade tips of the Fan. There may also be a build-up of material on the Fan Safety Guard. If this happens use the following cleaning technique:

1. Ensure the power to your Mega-Catch™ Mosquito Trap is disconnected. **(Attention: High-Speed Fan inside the Trap may cause injury if the power is not disconnected.)**
2. Unlock and remove the Lockable Door. Then lay the Trap on its side with the Door opening being face up.
3. Reach inside the Trap and remove the Fan Safety Guard (attached to base of Fan) by turning it counterclockwise (see figure 7).
4. Using a small sponge (1" x 1" x 3"(25mm x 25mm x 75mm)) and warm soapy water, reach into the Trap and carefully clean the inside casing of the Fan and the Fan blades.
5. Ensure that water is not allowed to enter into the Fan motor. Never hose water into the Fan.
6. Clean and then replace the Fan Safety Guard.
7. Leave the Trap to dry for at least 24 hours before recommencing operation.

FIG 7 - Removal of Fan Safety Guard

The casing of your Mega-Catch™

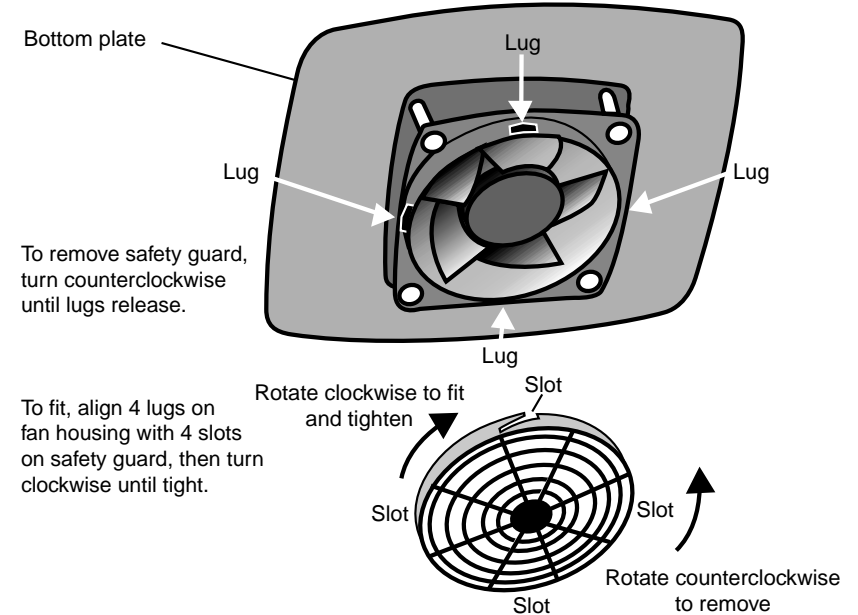

Mosquito Trap is made from polypropylene, which is extremely strong and durable. Its appearance is best maintained by a plastic protector of the type used on plastic car fenders. Do not use wax.

In order to prolong the life of your Mega-Catch™ Mosquito Trap store it and the Mega-Catch™ Stand / Mega-Catch™ Trolley in a dry place when not in operation. Your Mega-Catch™ Mosquito Trap should be serviced at the end of each season (see **Maintenance and Repair of Your Trap** section).

### Replacement of U.V. Bulb

The U.V. Bulb is a consumable item and replacements can be obtained from your Authorized Distributor. To install a new U.V. Bulb refer to the **Maintenance and Repair of Your Trap** section.

## Mega-Catch™ Octenol Fragrance Strip

Some, but not all, mosquito species are attracted to minute quantities of a chemical called octenol (1-OCTEN-3-OL). Each Mega-Catch™ Mosquito Trap comes with a Mega-Catch™ Octenol Fragrance Strip.

### To install or replace the Mega-Catch™ Octenol Fragrance Strip:

1. Ensure the power to your Mega-Catch™ Mosquito Trap is disconnected.
2. Unlock and remove the Lockable Door.
3. Remove the Mega-Catch™ Octenol Fragrance Strip from its pouch and be careful not to touch the exposed holes on its surface. Place the strip inside the Trap in the position shown in figure 7 below. Replace and lock the Door and remove the Key for child safety. Reconnect power. Wash your hands after this procedure has been completed.

FIG. 7 – Placement Position for Mega-Catch™ Octenol Fragrance Strip

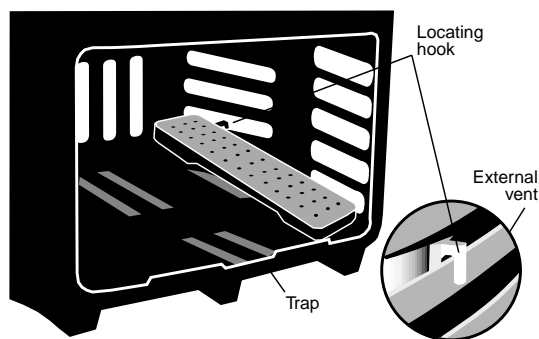

Place Mega-Catch™ Octenol Fragrance Strip in the trap as shown, and secure with the locating hook over the edge of the external vent

Mega-Catch™ Octenol Fragrance Strips should be effective for up to 30 days depending on weather conditions. Mega-Catch™ Octenol Fragrance Strips are a consumable item and replacements can be obtained from your Authorized Distributor.

(Note: Octenol can improve the rate of capture of some mosquito species. Other species [eg: the Asian Tiger Mosquito], may not be attracted - or even repelled - by octenol. You should determine what is best in your area by experimenting without the Mega-Catch™ Octenol Fragrance Strip in place.)

**ATTENTION: Keep Mega-Catch™ Octenol Fragrance Strips out of reach of children. Read directions and Important Safety Instructions carefully before use.**

## Optional Accessories

### 1. Battery Terminal Power Cable

The Mega-Catch™ Mosquito Trap can be operated using a 12-volt car battery as a power source. Your Authorized Distributor can supply a factory-approved Power Supply Cable complete with positive and negative alligator clips.

NOTE: Failure to connect the red positive + connector to the positive battery terminal and the black negative - to the negative battery terminal can result in major damage to your Mega-Catch™ Mosquito Trap and may void your warranty.

### 2. Cigarette Lighter/Car Accessory Terminal Cable

The Mega-Catch™ Mosquito Trap can be operated from your vehicle's accessory terminal using the factory-approved Accessory Cable. Your Authorized Distributor can supply a factory-approved Accessory Cable.

NOTE: Failure to use only the factory-supplied Cable could result in damage to your Mega-Catch™ Mosquito Trap and may void your warranty.

## Maintenance and Repair of Your Trap

Opening the two halves of the Mega-Catch™ mosquito Trap will be necessary for the following purposes:

- Replacement of U.V. Bulb (The U.V. Bulb should last for approximately two mosquito seasons, but, as with all light bulbs, life expectancy is variable depending on actual usage and climate.)
- Annual service (At the end of each season, the internal plates, heated reflective surface and Fan should be cleaned using warm soapy water and allowed to dry thoroughly.)
- Battery removal (The Programmable Timer contains a Nickel-Cadmium Battery. This must be disposed of correctly when the Trap reaches the end of its life.)

**Opening the Trap** (refer to figure 9.1):

**ATTENTION: Always disconnect the power to your Mega-Catch™ Mosquito Trap before opening the Trap.**

The two halves of the Trap are held together with 12 stainless-steel screws and nuts - six facing one way and six the other way.

Place the Trap on a table ensuring the Programmable Timer is on the side facing down. Remove the six screws facing toward you using a hex-head screwdriver.

Then turn the Trap over (so that it is "timer-side" up) and remove the remaining six screws and nuts.

Then lift the top half of the Trap away from the bottom half as if it was hinged at the top. The top half should now be "timer-side" down on the table and still connected to the bottom half by electrical cables.

The Top Plate holds the Mega-Catch™ Control Box (upside of Top Plate) and the U.V. Bulb and holders (underside of Top Plate). (NOTE: The Mega-Catch™ Control Box is a sealed unit and must not be opened.)

The Bottom Plate holds the heated reflective surface (upside of Bottom Plate) and the Fan (underside of Bottom Plate).

FIG. 9.1 – Opening the ULTRA Trap

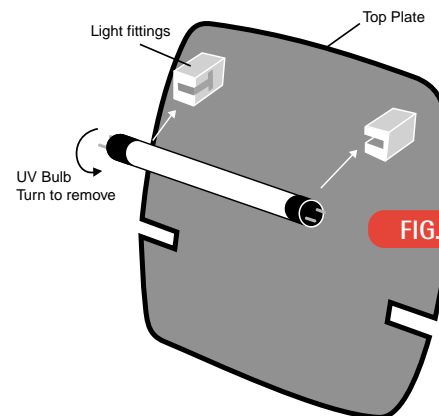
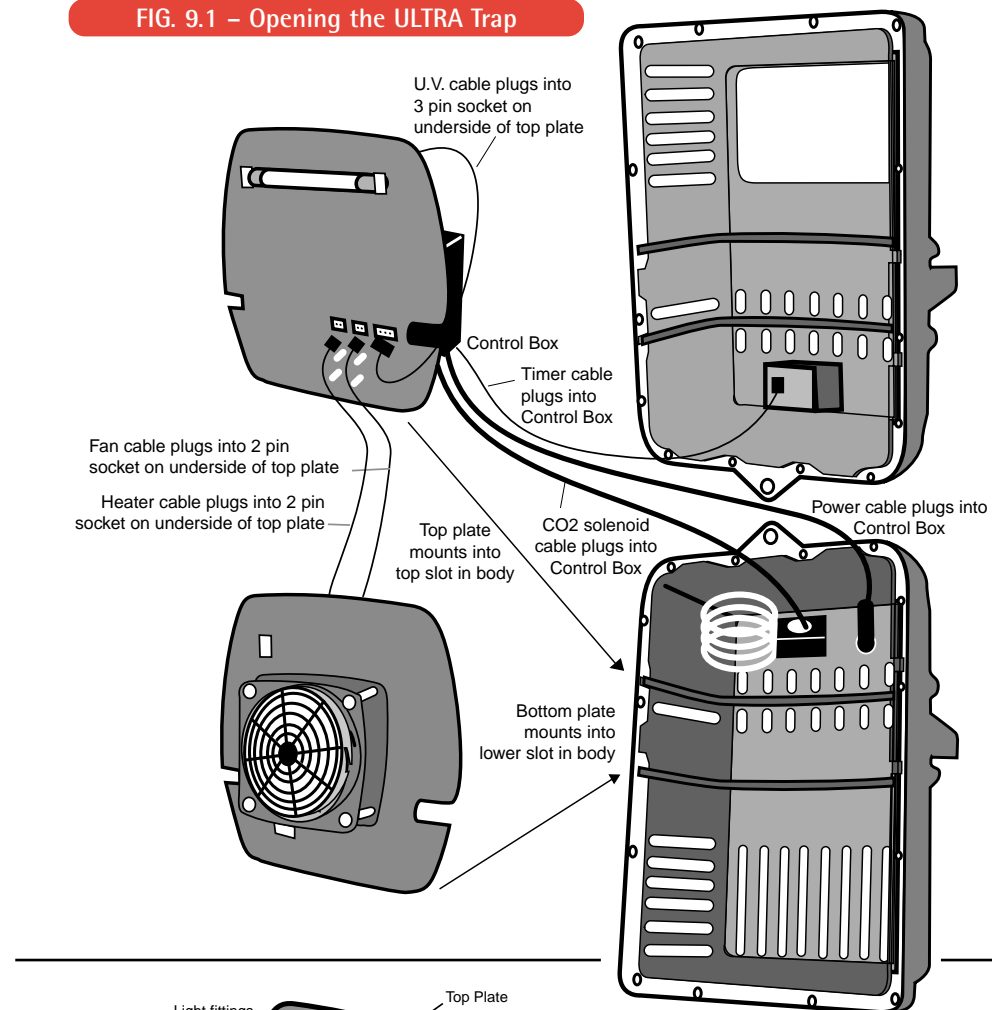

FIG. 9.2 – Replacement of U.V. Bulb

### **Replacement of U.V. Bulb** (refer to figure 9.2):

Remove the U.V. Bulb by twisting the tube gently until it is able to be removed. Then slot a new U.V. Bulb into the connector ends and twist the tube gently until it is firmly in position.

### **Reinstallation of Plates:**

You should not have any reason to remove the plates from the Trap. If however you do, merely slot the plates back into the ribs so that the Control Box is on the upper-side of the Top Plate and the Fan is on the under-side of the Bottom Plate. There are arrows on each plate that point to the back of the Trap (i.e. the half that does not contain the timer) when the plates have been properly installed.

### **Connection of Wires:**

You should not have any reason to remove any of the electrical connections except as part of the battery disposal process (see **Disposal of Timer** section). All electrical connections are by push-in pin connectors. Provided these are not forced it is not possible to plug any connector into the wrong connector hole.

There are three connector holes on the underside of the Top Plate. The two smaller two-pin connector holes are for the Fan and Heater cables. These two connections are interchangeable so it doesn't matter which of these two connector holes the Fan and Heater are plugged into. The third connection on the underside of the Top Plate is a three-pin hole and fits only the U.V. Bulb Connection Cable. The connection holes into the Control Box on the upperside of the Top Plate are all different sizes and fit the remaining cables.

### **Re-assembly of Trap:**

With the top and Bottom Plates in place replace the "timer-side" or top half of the Trap ensuring that each plate slots into the locating ribs. The 12 screw holes should now be aligned for replacement of the screws and nuts. Hold the nuts into the pre-formed hexagonal holes and carefully screw in the screws. (NOTE: Do not overtighten the screws. This could cause the nuts to rotate and damage the pre-formed hexagonal fittings in the plastic housing.)

## Disposal of Nickel-Cadmium Batteries

The Mega-Catch™ Mosquito Trap contains one Nickel-Cadmium Battery, which is used to energize the Programmable Timer. This battery is fitted in a sealed compartment at the rear of the Timer Unit. This battery must be recycled or disposed of properly.

### **To Remove the Timer Unit** (refer to figure 9.3):

Having opened up the two halves of the Trap:

1. Disconnect the cables from the Timer to the Mega-Catch™ Control Box by pulling the Timer Cable Pin from the Control Box
2. Using either your fingers or a screwdriver, lift up the two locating arms at the top and bottom of the Timer and then push the Timer Unit out from the inside of the Trap.

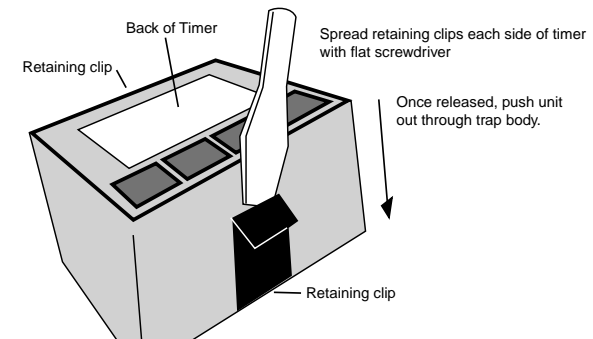

**FIG. 9.3 – Removal of Timer Unit**

### **Disposal of Timer**

It is illegal in many states and environmentally undesirable to dispose of the Timer Unit containing the battery in municipal trash. A fee has been paid to the Rechargeable Battery Recycling Corporation (RBRC) to collect these batteries and recycle them rather than incinerate or bury them. For information on our battery recycling program, call our toll-free consumer assistance number 1-800-231-9786 or call RBRC at 1-800-822-8837 for instructions on proper disposal.

## Frequently Asked Questions

### 1. How soon should my Mega-Catch™ Mosquito Trap begin to control mosquitoes?

The Mega-Catch™ Mosquito Trap will begin to catch immediately there is mosquito activity in the area. Female mosquitoes looking for blood will be drawn to the Trap and destroyed. The Trap will gradually reduce your mosquito population as it attracts and destroys them. It may take 6-8 weeks of use to reduce the mosquito population to the point that you have successfully interrupted the breeding cycle.

### 2. How often do I need to operate my Mega-Catch™ Mosquito Trap?

Before using your Mega-Catch™ Mosquito Trap note the time of day when mosquito activity is greatest. If, for example, this is in the morning and the evening, then you should set the Trap (using the Programmable Timer) to operate at these times. Where your mosquito problem involves night time biters, we recommend operation of the Trap between 7pm and 11pm and 4am and 8am. If mosquito activity is all day, then you may need to operate the Trap 24 hours per day until the mosquito population declines.

### 3. Is the Mega-Catch™ Mosquito Trap harmful to me or my pets?

No. The Mega-Catch™ **ULTRA** Mosquito Trap can be used outside around humans and pets provided it is operated in accordance with the instructions in this operation manual. **Ensure you read the Important Safety Instructions at the start of this operation manual.**

### 4. How many Traps should I buy for around my house?

This depends on the size of your property. Generally we recommend one or two Traps depending on the number and location of mosquito breeding areas on your property. A Mega-Catch™ Mosquito Trap can, in favorable weather conditions, attract mosquitoes from up to 150 feet away.

### 5. Will Mega-Catch™ Mosquito Traps catch biting flies?

The Mega-Catch™ **ULTRA** Mosquito Trap will catch sandflies, black flies and biting midges (no-see-ums) and some other biting insects.

### 6. Can I stop my Mega-Catch™ Mosquito Trap from catching moths?

The Mega-Catch™ Mosquito Trap incorporates a low-intensity U.V. Bulb that emits light at a frequency our research has shown to attract certain mosquito species. Unfortunately it can also attract small quantities of non-target species like moths. If this is a problem, the U.V. Bulb can be switched off by touching the "U.V. Tube" button on the Programmable Timer.

## Problem Solving

### If your Mega-Catch™ Mosquito Trap fails to operate:

- Check that the Power Cable is properly connected to both the Trap and the mains, and that the power is switched on.
- Check that the Programmable Timer is set to the "ON" position.
- Check that the Programmable Timer, if set to AUTO, is set to operate at the time you are checking its operation.

If these steps fail then contact us at [info@megacatch.com](mailto:info@megacatch.com) - or call the Service Centre number shown on the separate Warranty Certificate.

### If the lights in the Mega-Catch™ Mosquito Trap come on but the Fan fails to operate:

- Check whether there has been a build up of material in the Fan and/or Fan Safety Guard which is preventing the Fan blade from turning (Refer to **Care of Your Trap** section).

If these steps fail then contact us at [info@megacatch.com](mailto:info@megacatch.com) - or call the Service Centre number shown on the separate Warranty Certificate.

NOTE: Do not attempt to access the internal electronic components of your Mega-Catch™ Mosquito Trap. Opening of sealed units will void your warranty.

## Need Help?

For service, repair or any questions concerning Mega-Catch™ products, contact us at [info@megacatch.com](mailto:info@megacatch.com) - or call the Service Centre number shown on the separate Warranty Certificate. Do NOT return products to the place of purchase. Do NOT return products to an Authorized Distributor.

You may also want to consult our website: [www.megacatch.com](http://www.megacatch.com).

## Specifications

Power Source	AC Adaptor 57C.YL-36-12V
CSA Listing	190966 (LR115247)/1439468
Input	120V – 60Hz 36 VA
Output	12V – Max 30VA

U.S. Design Patent No: 449,091

U.S. Patent No: 6,199,316

U.S. Trade Mark Reg. No: 2,679,688

## Parts List

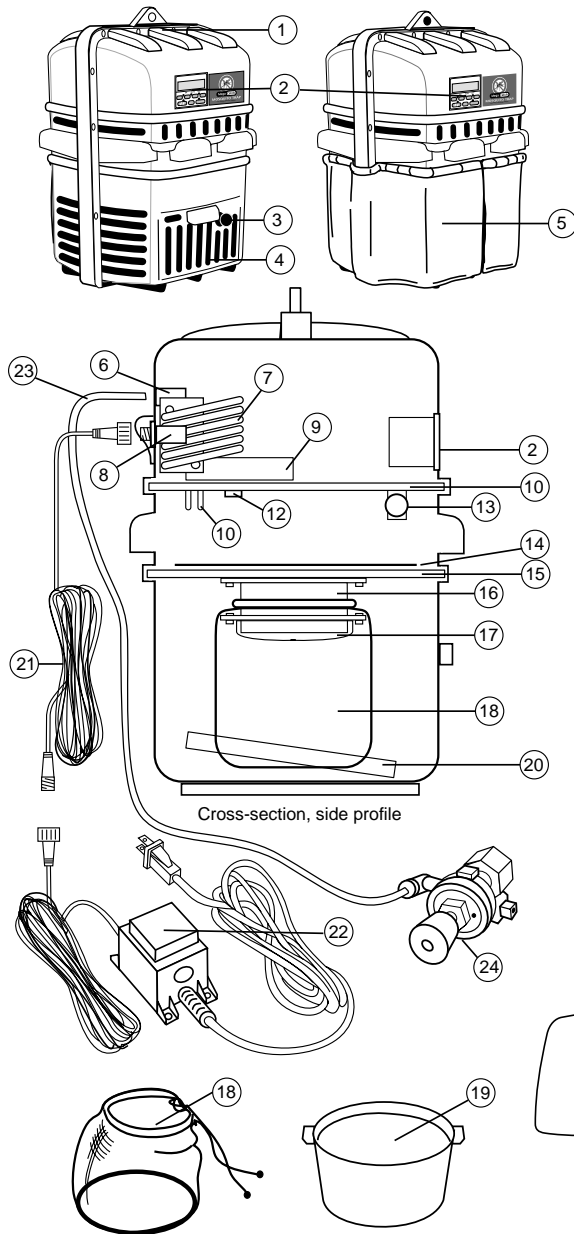

Description	Part No.
1. Mega-Catch™ Ultra Mosquito Trap	MCU-400
2. Programmable Timer	MC-U01
3. Key	MC-PU208
4. Lockable Door	MC-PU203
5. External Skirt	MC-PU112
6. CO <sub>2</sub> Gas Solenoid	MC-U303
7. CO <sub>2</sub> Gas Release System	MC-U306
8. Power Connection	
9. Control Box	MC-U05
10. Top Plate	MC-PU205
11. Light emitting Diodes	
12. Internal Power connectors	
13. UV Tube	MC-PU2
14. Reflective Surface	MC-PU211
15. Bottom Plate	MC-PU206
16. Fan Unit	MC-PU210
17. Fan Safety Guard	MC-PU209
18. Catch Bag	MC-PU111
19. Liquid Catch Container	MC-PU204
20. Octenol Fragrance Strip	MC-PU224
21. 60ft Extension Cord	MC-PU7
22. Transformer	MC-U20
23. CO <sub>2</sub> Gas tubing	MC-U305
24. CO <sub>2</sub> Gas Regulator	MC-U301



Product made in New Zealand by:  
 Envirosafe Technologies NZ Limited  
 16th Floor, 120 Albert Street  
 Auckland, New Zealand  
[info@megacatch.com](mailto:info@megacatch.com) [www.megacatch.com](http://www.megacatch.com)

Pub. No. 1000000006  
 Printed in New Zealand  
 Mega-Catch™ is a trademark of Envirosafe Technologies NZ Ltd.